

Features and Benefits

- Four grades of magnetic materials
- Cost effective design
- High resistance to demagnetization
- Operation from -40°C to 125°C
- Tough environmental endurance
- Very resistant to chipping

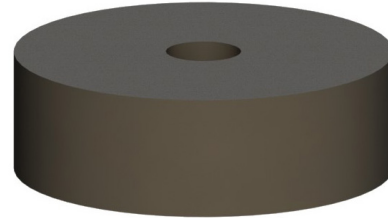

Molded Target Magnet

Physical Properties of Magnetic Material

Table 1.1

Characteristic	Value	Units
Tensile Strength	6500	PSI
Flexural Strength	9750	PSI
Flexural Modulus	1.3 X 10 ⁶	PSI
Continuous Service Temperature	100	°C

Magnetic Properties

Table 1.2

Characteristic	Magnalox 300	Neobond 12M	Neobond 30M	Neobond 32P	Units
Remanence (B _r)	1370	2500	4000	4300	Gauss
Coercive Force (H _c)	1180	2400	3250	2500	Oersted
Energy Product (BH _{MAX})	0.40	1.3	3.1	3.2	MGOe
Intrinsic Coercive Force (H _{ci})	2300	7500	7000	6900	Oersted
Reversible Temperature Coefficient (B _r)	-0.2	-0.35	-0.4	-0.4	%/deg C
Reversible Temperature Coefficient (H _{ci})	+0.5	-0.25	-0.36	-0.40	%/deg C
Peak Magnetizing Force (>95% Saturation)	596	1100	1600	1600	kA/m
Specific Gravity	3.5	4.0	4.7	4.45	---

Pole Counts

Alternating north and south magnetic poles are symmetrically located on the outer diameter for radial sensing.

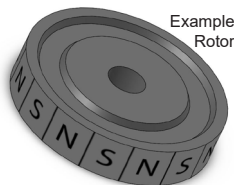

Note: (N)orth/(S)outh markings are for illustration and do not appear on the actual product.

Available Pole Counts	4, 6, 8, 10, 12, 16, 24
-----------------------	-------------------------

Target Rotor Physical Outline - Molded (Mounting Style A)

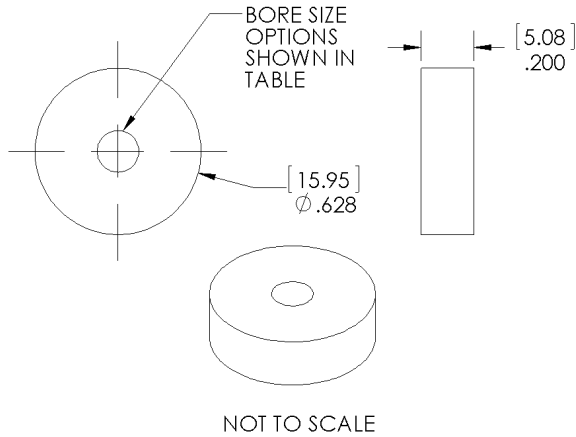

Table 2.1

Bore Size (.inch)	Motor Shaft OD Size (nominal)	NEMA Guide Shaft Tolerance	Magnet Bore MIN. (inch)	Magnet Bore MAX. (inch)
079	2 mm (.0787")	+0.0000"/-0.0005"	.0777	.0807
118	3 mm (.1181")		.1171	.1201
125	1/8 in (.1250")		.1240	.1270
156	5/32 in (.1563")		.1553	.1583
157	4 mm (.1575")		.1565	.1595
188	3/16 in (.1875")		.1865	.1895
197	5 mm (.1969")		.1959	.1989
236	6 mm (.2364")		.2354	.2384
250	1/4 in (.2500")		.2490	.2520
276	7 mm (.2758")		.2747	.2777
313	5/16 in (.3125")		.3115	.3145
315	8 mm (.3150")		.3140	.3170
375	3/8 in (.3750")		.3740	.3770

Other bore sizes available upon request.
Contact sales@phoenixamerica.com.

Target Rotor Mounting Guidelines - Molded (Mounting Style A) For Slip Fit Application

- Proper alignment of the target rotor is critical for optimal performance.
- A machined step on the motor shaft provides a quick and repeatable method for positioning the target rotor. Spacers or other fixturing should be used to properly position the rotor if no mechanical locating features are on the shaft.
- Various adhesives can be used to bond the target rotor to the motor shaft. Shaft alloys, operating environment, and shaft speed and acceleration should be taken into consideration when selecting an appropriate bonding agent. Loctite threadlockers and retaining compounds have proved effective in bonding the target rotor to the motor shaft. Loctite 263 and 2760 threadlockers and Loctite 638 and 680 retaining compounds are good candidates. These materials have been effective in past experience; testing under actual operating conditions should be used to qualify any bonding material.
- For best results, the motor shaft should be clean and free of any oils, lubricants, or solvents.
- Apply adhesive around the leading edge of the shaft and inside the hole in the rotor. Use a rotating motion when assembling the magnet to the shaft to insure good adhesive coverage.
- The use of primers and activators can be used to improve bond strength and cure rate.
- For non-critical applications or for fast bonding for evaluation, a cyanoacrylate adhesive (super glue) can be used. Loctite 401 and 410 have proven effective for quick bonding applications.

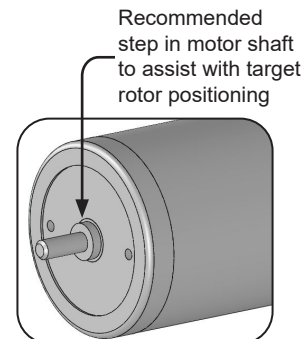
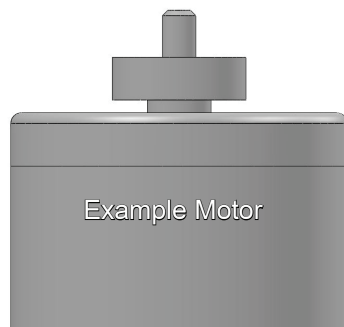

Part Number Description

G10	A	125	25	R08
Series	Design Style	Bore Size	Magnet Material	Pole Count
G10	<i>A Molded</i>	079 2 mm 118 3 mm 125 1/8 in <i>(default)</i> 156 5/32 in 157 4 mm 188 3/16 in 197 5 mm 236 6 mm 250 1/4 in 276 7 mm 313 5/16 in 315 8 mm 375 3/8 in	25 <i>Magnalox 300</i> 50 <i>Neobond 12M</i> 75 <i>Neobond 30M</i> 85 <i>Neobond 32P</i>	R04 4 Poles R06 6 Poles R08 8 Poles R10 10 Poles R12 12 Poles R16 16 Poles R24 24 Poles

Example: G10-A-125-25-R08